

# 36<sup>TH</sup> SPRING RALLY

June 13<sup>th</sup>, 2021



## SUPPLEMENTARY REGULATIONS



**Organised by**

The Automobile and Touring Club of Lebanon  
P.O. Box 115 - Jounieh / Lebanon  
Tel.: +961-9-640220 / 640567 / 932020  
Fax: +961-9-640579 / 934662  
e-mail: [atcl@inco.com.lb](mailto:atcl@inco.com.lb)  
web site: [www.atcl.org](http://www.atcl.org)



CHAMPIONNAT DU LIBAN  
**ATCL**  
DES RALLYES

---

## **CONTENTS:**

	<b><u>Page</u></b>
<b>1. Introduction</b>	<b>3</b>
<b>2. Organisation and Description</b>	<b>3</b>
<b>3. Programme and Deadlines</b>	<b>5</b>
<b>4. Entries</b>	<b>6</b>
<b>5. Insurance</b>	<b>10</b>
<b>6. Advertising &amp; Identification Numbers</b>	<b>11</b>
<b>7. Tyres</b>	<b>11</b>
<b>8. Fuel</b>	<b>12</b>
<b>9. Reconnaissance</b>	<b>14</b>
<b>10. Administrative Check</b>	<b>15</b>
<b>11. Scrutineering, Sealing and Marking</b>	<b>16</b>
<b>12. Other Procedures</b>	<b>19</b>
<b>13. Identification of Officials</b>	<b>21</b>
<b>14. Prizes</b>	<b>21</b>
<b>15. Final Checks and Protests</b>	<b>22</b>
<b>APPENDIX 1 Itinerary</b>	<b>24</b>
<b>APPENDIX 2 Reconnaissance Schedule</b>	<b>25</b>
<b>APPENDIX 3 Competitors' Relations Officers</b>	<b>26</b>
<b>APPENDIX 4 Advertising and Identification Numbers</b>	<b>27</b>
<b>APPENDIX 5 Extracts from FIA Appendix L</b>	<b>29</b>
<b>APPENDIX 6 Mounting of On-Board Cameras</b>	<b>31</b>
<b>APPENDIX 7 Start Light Sequence</b>	<b>33</b>

# 1 - INTRODUCTION

## 1.1 - Announcement

This rally will be run in compliance with the FIA International Sporting Code and its appendices, the 2021 FIA Regional Rally Sporting Regulations, the National Sporting Code which comply with the FIA regulations and these Supplementary Regulations.

Modifications, amendments and/or changes to these Supplementary Regulations will be announced only by numbered and dated Bulletins (issued by the Organiser or the Stewards)

The 2021 FIA Regional Rally Championships Sporting Regulations can be found at: <http://www.fia.com/regulation/category/117>

## 1.2 - Road surface

The rally will be run on **Tarmac**.

## 1.3 - Overall SS distance and total distance of the itinerary

SS distance: 66.68 kms.

Total distance: 232.27 kms.

# 2 - ORGANISATION AND DESCRIPTION

## 2.1 – National titles for which the rally counts

- The 2021 Lebanese Rally Championship for Drivers.
- The 2021 Lebanese Rally Championship for Co-Drivers.
- The 2021 Lebanese Cup for RC2/N4 Rally Drivers.
- The 2021 Lebanese Cup for RC3 Rally Drivers.
- The 2021 Lebanese Cup for RC4 Rally Drivers.
- The 2021 Lebanese Cup for RC5 Rally Drivers.
- The 2021 Lebanese Cup for Junior Rally Drivers/Co-Drivers.
- The 2021 Ladies Cup for the Lebanese Championship.

## 2.2 - Visa numbers - ASN:

ASN visa No: **R/1/2021**

Issued on: **March 22<sup>nd</sup>, 2021**

## 2.3 - Organiser's name, address and contact details (permanent office)

The Automobile and Touring Club of Lebanon - ATCL  
Kaslik; Jounieh

National Sporting Committee / Permanent Secretariat  
**36<sup>th</sup> Spring Rally Office**

P.O. Box 115 - Jounieh / Lebanon  
Tel.: +961-9-640220 / 640567 / 932020  
Fax: +961-9-640579 / 934662  
e-mail: [atcl@inco.com.lb](mailto:atcl@inco.com.lb)  
website: [www.atcl.org](http://www.atcl.org)



## 2.4 - Organisation committee

Chairman	Gabriel Hayek
Members	Fady Aoun Dr. Guy Hokayem Nicolas Hindi Me. Ziad Jamous Raffi Khederlarian Serge Tchoupourian

## 2.5 - Stewards of the Meeting

Chairman of the Panel	Sleiman Khtattar (Chairman) Fady Aoun Issam Hitti
Secretary to the Stewards	Nivine Hachem

## 2.6 - Observers and Delegates

ASN Sporting Delegate	Gaby Kreiker
-----------------------	--------------

## 2.7 - Senior Officials

Clerk of the Course	Gabriel Hayek
Deputy Clerk of the Course	Me. Ziad Jamous
Assistant Clerk of the Course	Lydia Labaki
Chief Safety Officer	Nicolas Hindi
Scrutineers	Raffi Khederlarian (Chief) Hovsep Aslanian (Assistant Chief) Serge Tchoupourian (Assistant Chief) Georges Haddad Khalil Hashem Edgard Kfoury Ardem Sarkissian
Competitors' Relations Officer	Michel Schucry
Chief Medical Officer	Dr. Guy Hokayem
COVID-19 Response Coordinator	<b>T.B.A.</b>
Media Relations Officer	Jalal Beaino
Tracking Monitoring Officer	Neeman Hatem
Results Officer	Fady Eid
Secretary of the Rally	Michael Hayek
Judges of Fact:	All the named senior officials on this page.

## 2.8 - HQ location and contact details

The Rally HQ is located at:

**Casino du Liban**  
Maameltein; Lebanon  
e-mail: [atcl@inco.com.lb](mailto:atcl@inco.com.lb)  
Web site: [www.atcl.org](http://www.atcl.org)

## 2.9 - Location of Holding Area

The Holding Area is located at Casino du Liban – Maamltein;

## 2.10 - Location of Service park(s)

The Service Park is located at LBCI Parking – Adma.

# 3 - PROGRAMME AND DEADLINES: (IN CHRONOLOGICAL ORDER)

### Wednesday May 12<sup>th</sup>, 2021

13:00hrs	Opening date for entries.	Rally Office A.T.C.L.; Jounieh
----------	---------------------------	-----------------------------------

### Tuesday June 8<sup>th</sup>, 2021

12:00hrs	Submittal of Fuel Purchase Form.	TOTAL Liban Ashrafieh; Beirut
16:30hrs	Closing date for entries.	Rally Office A.T.C.L.; Jounieh
16:30hrs	Closing date for co-driver details.	Rally Office A.T.C.L.; Jounieh
16:30hrs	Closing date for submitting all Forms.	Rally Office A.T.C.L.; Jounieh

### Wednesday June 9<sup>th</sup>, 2021

09:00hrs	Publication of the Entry List on the official notice board.	Rally Office A.T.C.L.; Jounieh
09:00 till 13:00hrs	Collection of material and documents.	Rally Office A.T.C.L.; Jounieh
09:00hrs	Media accreditation.	Rally Office A.T.C.L.; Jounieh
16:00hrs	Publication of convocations to administrative checks and scrutineering.	Rally Office A.T.C.L.; Jounieh

### Thursday June 10<sup>th</sup>, 2021

12:00 till 16:00hrs	Issuing of the Road-Book.	Rally Office A.T.C.L.; Jounieh
---------------------	---------------------------	-----------------------------------

### Friday June 11<sup>th</sup>, 2021

08:30hrs	Reconnaissance starts	
17:00hrs	Reconnaissance ends.	
16:30 till 20:00hrs	Administrative Checks (Convocations will be carried out according to an individual time schedule).	Rally Office A.T.C.L.; Jounieh
17.00 till 20.30hrs	Scrutineering - sealing and marking. The administrative checks must be completed before the scrutineering of	Tennis Courts Venue A.T.C.L.; Jounieh



the cars. Convocations will be carried out according to an individual time schedule.

20:45hrs First stewards' meeting. Rally Office  
A.T.C.L.; Jounieh

### Saturday June 12<sup>th</sup>, 2021

11:00hrs Publication of Start List for Section 1/  
Leg 1, on the official notice board. Rally Office  
A.T.C.L.; Jounieh

### Sunday June 13<sup>th</sup>, 2021

05:30hrs Opening of the Rally Headquarters. Casino du Liban  
Maameltein; Lebanon

06:00 till 06:30hrs Car entry to the starting Holding Area. Casino du Liban  
Maameltein; Lebanon

07:00hrs Rally Start. Casino du Liban  
Maameltein; Lebanon

14:30hrs Finish Ceremony and Prize-giving. Casino du Liban  
Maameltein; Lebanon

15:00hrs Final scrutineering. Casino du Liban  
Maameltein; Lebanon

16:00hrs Publication of the Provisional Final  
Classification. Casino du Liban  
Maameltein; Lebanon

16:30hrs Publication of the Official Final  
Classification. Casino du Liban  
Maameltein; Lebanon

### Official Notice Board

- Thursday June 10<sup>th</sup>, 2021 to Saturday June 12<sup>th</sup>, 2021

#### **Rally Secretariat**

The Automobile and Touring Club of Lebanon  
Kaslik; Jounieh  
National Sporting Committee Office

- Sunday June 13<sup>th</sup>, 2021

#### **Rally Headquarters**

Casino du Liban  
Maameltein; Jounieh

#### **Digital Notice Board**

**T.B.A.**

## 4 - ENTRIES

### 4.1 – Closing date for entries

Tuesday June 8<sup>th</sup>, 2021 at 16:30hrs.

## 4.2 - Entry procedure

Any person wishing to take part in the 36<sup>th</sup> Spring Rally must complete and send the entry form (including co-driver details) to the Rally Office (for address details please refer to Art. 2.3 of this Supplementary Regulations).

All entry forms must be signed by the entrant and each crew member prior to the start of testing and/or reconnaissance. Foreign competitors must hold an authorisation from their parent National Sporting Authority.

Entry forms will only be accepted if accompanied by:

- The total amount of the entry fees.
- A deposit against the tracking devices.
- Photocopy of the first page of the homologation book for the car.
- Photocopy of the entrant / competitor licence.
- Photocopies of crew members' competitions licences.
- Photocopies of crew members' valid driving licences.
- A letter from the owner of the car and/or a power of attorney (if the car is not the property of the crew members).

## 4.3 - Number of entrants accepted and classes

The maximum number of entries is 40 cars. If more than 40 entries are received, the Organisers reserve the right to decide which entries (among the non-priority drivers) to be accepted.

## 4.4 - Classes and Groups

The eligible vehicles to participate in rallies are as follows:

### a) Homologated Vehicles

The eligible vehicles to participate in rallies are as follows:

All vehicles classes described in Article 12.1 of the 2021 FIA Regional Rallies Championships Sporting Regulations, excluding RGT class cars. The concerned cars must be in conformity with Appendix J of the F.I.A International Sporting Code for the running year.

### Additional provisions

- Cars homologated as Kit Car and Super 1600 are not allowed.
- For drivers entered with a Rally2 car complying with 2021 Appendix J, Art. 261, it will be possible to use the old part after applying a joker (except reliability and safety jokers).
- For drivers entered with a Super 2000-Rally car complying with 2013 Appendix J, Art. 255A, it will be possible to use lapsed errata without any penalty.
- The complete original FIA homologation form and other necessary certifications must always be available.

### b) Vehicles with Expired Homologations

- i. Cars whose homologations have expired and, still accepted by the FIA, up to a maximum of eight years before the beginning of the current year, *i.e. Jan 1<sup>st</sup> 2013 up to Dec 31<sup>st</sup> 2020*.
- ii. ASN Approved Cars, according to Article 12.3.6 of the 2021 FIA Regional Rallies Championship Sporting Regulations whose homologations have expired between nine and twelve years before



the beginning of the current year, *i.e. Jan 1<sup>st</sup> 2005 up to Dec 31<sup>st</sup> 2012.*

- iii. It is **MANDATORY** for these vehicles within this category:
- be in conformity with the safety requirements as stipulated in Appendix J, Art. 253.
  - Cars homologated as Kit Car and Super 1600 are not allowed.
  - be in conformity with their expired homologation forms.
  - an ASN technical passport is mandatory.

#### c) National Cars

Vehicles whose FIA homologation have expired between Jan. 1<sup>st</sup> 1993 and Dec. 31<sup>st</sup> 2012.

It is mandatory to these vehicles to be in conformity with their expired homologation forms and the current FIA Appendices J 253 for safety equipment J 254 for Group N cars and J 255 for group A.

#### Additional provisions for National Cars

- Cars homologated as Kit Car and Super 1600 are not allowed.
- All cars must be fitted with two manual fire extinguishers, each having 2kgs minimum capacity of powder extinguishant. However, an additional mounted extinguishing system in compliance with the current FIA standard 8865-2015 is highly recommended.
- The fitting of FIA approved fuel tanks is highly recommended, otherwise the series production tank should be retained.
- Locally fabricated ROPS; Roll over Protection Structures (Roll cages) **are prohibited**.
- Groups & Classes for National cars;
  - Group N:
    - LN1: Up to 1400cc
    - LN2: Over 1400cc Up to 1600cc
    - LN3: Over 1600cc Up to 2000cc
    - LN4: Over 2000cc Up to 3500cc
  - Group A:
    - LA5: Up to 1400cc
    - LA6: Over 1400cc Up to 1600cc
    - LA7: Over 1600cc Up to 2000cc

#### 4.5 - PROMOTION classification

There will be a PROMOTION classification for the Lebanese competitors with the following conditions:

- To hold the Lebanese nationality and competition licence.
- Not to be FIA priority driver.
- Not to be MERC priority driver.
- Not to be an ASN priority driver.
- The car must be the property of one of the crew members and not the property of any dealer or manufacturer.
- Have not been classified among the first 3 during the past two years at the Rally of Lebanon.

A list of PROMOTION classification will be issued at the same time along with the entry list.



#### 4.6 - Entry fees and entry packages

4.6.1 The entry fees are as follows:

- a) With the optional advertising proposed by the Organisers
  - \* For Private Entrant USD 1,200.- U.S. \$
  - \* For Legal Entrant USD 2,000.- U.S. \$
- b) Without the optional advertising proposed by the Organisers
  - \* For Private Entrant USD 2,000.- U.S. \$
  - \* For Legal Entrant USD 3,000.- U.S. \$

**Private Entrant:** For an entry for the 36<sup>th</sup> Spring Rally to be considered as a private entry, the following conditions must be complied with:

- a) The car entered must be personal property of one of the crew members and the car licence must be in his/her name.  
If the car is not the property of one of the crew members, a letter of authorisation from the owner of the car and/or a power of attorney approving the use of the car should be accompanied along with the entry form.  
Letters of authorisation and/or powers of attorney dated more than three months before the date of the rally will not be considered.
- b) The entry form must be made in the name of one of the crew members, not in the name of a sponsor or any commercial organisation.
- c) The entrant's competition licence must be in the name of one of the crew members.

Unless all of the above-mentioned conditions are met, the entry will not be considered as a private entry and the appropriate entry fees will be liable for payment.

**Legal Entrant:** The competing car entered by a team, a manufacturer, a company or other legal entity (with legal entrant / competitor's licence).

4.6.2 The entry fees specified in Article 4.6.1 (aforementioned) include:

Item	Private Entrants	Legal Entrant
Driver Passes	2	2
Service Personnel Passes	6	8
"Service" plates	1	2
Road Book	1	1

Should additional material deem necessary; it can be ordered from the rally secretariat by using the "Additional materials order form".

4.6.3 The change of one crew member will be subject to article 22.4 of the 2021 FIA Regional Rally Sporting Regulations. However, an additional fee of 50.- U.S. \$ will be imposed in case of changing a crew member.

#### 4.7 - Payment details

Entry Fees can be remitted to the Organiser's Bank Account:

Bank: BLOM Bank (Banque du Liban et d'Outre-Mer)  
Bank address: Kaslik Branch



CHAMPIONNAT DU LIBAN  
**ATCL**  
DES RALLYES

Account N°: 023 - 02(300) 067 36 21 - 1 - 6(44037) and to the order of The Automobile and Touring Club of Lebanon

IBAN: LB21 0014 0000 2302 3000 6736 2116

SWIFT CODE: BLOMBBX

Any bank charges incurred by a swift transfer must be charged to the sender's account.

Entry fees paid by bank transfer shall simultaneously be advised to the Rally Office by fax and/or e-mail to ensure that payment is received in full prior to the close of entries.

#### 4.8 - Refunds

Entry fees will be refunded in full:

- a) To candidates whose entry has not been accepted.
- b) In case the 36<sup>th</sup> Spring Rally does not take place.
- c) Organisers may refund up to 30% of the entry fee to those competitors who, for reasons of “force majeure” (duly certified by their ASN), were unable to start in the rally.

## 5 - INSURANCE

- a) The insurance guaranties the competitors for civil liability towards third parties for a maximum of USD 100.000 as total liability for this event. The insurance cover will come into effect from the start until the end of the rally or at the moment of permanent retirement, disqualification or exclusion.
- b) Beside the insurance provided by the organisers, it is compulsory for all entrants / competitors to have their rally vehicle covered by a third-party liability, during their stay in Lebanon.  
A copy of the insurance certificate should be presented along with other documents upon administrative checks (refer here under to Art. 10.3 of these Supplementary Regulations).
- c) It is mandatory that all foreign crew members have Motor Sport Personal Accident Insurance valid for Lebanon, or a Prise-en-Charge issued by the crew members parent ASN. Otherwise, the Organiser will provide such insurance for a premium of 250. - U.S. \$.
- d) The service, management vehicles and reconnaissance vehicles including those bearing special plates issued by the Organisers may never be considered as official participants in the rally. They are therefore not covered by the insurance policy of the rally and will remain the sole responsibility of their owners.
- e) Damages to rally cars as well as liability of a crew member towards the other crew member or car are not covered by the insurance provided by the Organisers.
- f) **Incident involving a person who is not a crew member**  
In compliance with the 2021 FIA Regional Rally Sporting Regulations Article 53.4 of as well as Appendix H Article 5.6.1, if a crew is involved in an accident in which a person who is not a crew

member sustains physical injury, the car must stop immediately, and the procedure as laid down in Article 53.3.1 (2021 RRSR) must be followed.

The Lebanese traffic law will be complied with in relation to procedures at accidents.

Moreover, it is compulsory for the competitor or his representative to notify the Clerk of the Course and/or the Competitor's Relations Officer(s) in writing, within 4 hours, with the full details including the names and addresses of those involved and witnesses if any.

Any breach of this rule will be reported and will result in a penalty, at the discretion of the Stewards.

## 6 - ADVERTISING AND IDENTIFICATION

### 6.1 - Advertising

- a) The advertising of tobacco products is prohibited.
- b) Advertising regarding alcoholic beverages is permitted.
- c) The advertising of political, religious and/or social material is strictly forbidden.
- d) Competition numbers, rally plates and advertising shall be affixed on the car before scrutineering. These must be visible through the whole duration of the rally under the pain of penalty (Article 6.2-b of these Supplementary Regulations.).
- e) Spaces set by the Organisers (refer to Appendix 4 of this Supplementary Regulation) must be reserved on the car, if the entrant has accepted the Organiser's optional advertising, unless he pays the Entry Fees without Optional Advertising proposed by the Organisers in accordance with Article 4.6.1-b of this Supplementary Regulation.

### 6.2 - Identification numbers

- a) The rally plates and numbers will be provided by the Organisers in compliance with the FIA Regional Rally Sporting Regulations. These numbers must be affixed as specified in Appendix 4.
- b) The missing and/or covering of a rally plate will result in a cash penalty of 100. - U.S. \$
- c) Service and/or auxiliary vehicle plates shall be affixed on the inside of the windscreen in the top right-hand corner of the vehicle.

## 7 – TYRES

In accordance with the Appendix C of the 2021 National Sporting Code FIA homologated tyres are recommended to be used; however, the following are permitted:

- a) Moulded FIA approved tyres in compliance with Article 60 of the 2021 FIA Regional Rally Sporting, read in conjunction with Article A.2 of Appendix V, and the current homologation list of asphalt

- eligible tyres for FIA rallies found on <https://www.fia.com/regulation/category/117>
- b) Tyres commercially and readily available marked “DOT”, “E” or “e” for street use and NOT for Racing / Competition / Track Use, etc..., are permitted. Slick tyres are NOT permitted. Any type of tire SHOULD be submitted for final approval, latest TWO WEEKS BEFORE the event, to the organizing committee of the event. Acceptance of the said tyres is conditioned by the committee’s final approval.
  - c) For all the above-mentioned tyres, Hand cutting or modification of the thread pattern is **NOT** permitted.
  - d) The organisers have the right to reject any tyre without having to give a reason.
  - e) **Tyres on use for reconnaissance**  
Complying with Article 35.2.a of the 2021 FIA Regional Rally Sporting Regulations, only road-homologated series production tyres for asphalt are authorised for reconnaissance.

Any breach of the tyre regulations will be submitted to the Stewards and may result in a penalty, which may go as far as the disqualification of the crew by the Stewards.

## 8 – FUEL

### 8.1 Fuel supply

**8.1.1** - Throughout the 36<sup>th</sup> Spring Rally all entered cars shall **SOLELY** use fuel supplied by “TOTAL Liban”, which meets the technical requirements of FIA Appendix J.

**8.1.2** - Two types of petrol are available:

- a) **TOTAL EXCELLIUM RALLY** (50 litre canisters), sold at the price of \$ **7.70** /litre VAT included.
- b) **TOTAL EFFIMAX 95 octane**, sold at current price of the market at delivery time, VAT included.

**8.1.3** - “TOTAL Liban” will supply the fuel needed for the adjustments, against request and upon payment.

**8.1.4** - Closing date for ordering fuel

- a) Each competitor must fill in and submit the special Fuel Purchase Form requesting the quantity of fuel needed for the rally and send it, no later than 12:00hrs on Tuesday June 8<sup>th</sup>, 2021, to:

TOTAL Liban  
Total Beirut Bldg., 2<sup>nd</sup> floor  
Rue Ashrafieh  
Ashrafieh; Beirut; Lebanon

P.O. Box 11-3636 - Beirut / Lebanon  
Tel.: +961-1-212250 Fax: +961-1-216014  
e-mail: [michel.hajjar@total-liban.com](mailto:michel.hajjar@total-liban.com)

- b) Payment details:  
Payments can be remitted to the supplier’s bank account:  
Bank: Bank Audi

Bank address: Centre SOFIL, Ashrafieh Branch  
 IBAN: LB86 0056 0002 0206 7421 0020 0936  
 Devise: USD  
 SWIFT CODE: AUDBLBBX

Any bank charges incurred by a swift transfer must be charged to the sender's account.

Moreover, a copy of fuel purchase invoice should be presented along with other documents in the administrative checks.

In case of failure to collect part of the fuel, the purchaser will be refunded with the corresponding amount of the remaining fuel in sealed canisters ONLY for TURBO, Turbo REF type, within 15 days after the end of the rally.

### 8.1.5 Fuel dispense

The fuel will be dispensed to the competitor or his representative (duly assigned in writing) at the refuelling zone – as indicated in the Road-Book - subject to presenting the voucher given by “TOTAL Liban” and in compliance with the schedule filled on the Fuel Purchase Order and mutually agreed upon between “TOTAL Liban” and the purchaser.

It is the competitors’ responsibility to fill the appropriate form given by TOTAL Liban regarding the quantity to be dispensed at each of the refuelling zones in the rally.

## 8.2 General provisions

- a) The fuel tank capacity should meet and cover the time and distance table of the rally, *i.e. the rally itinerary*.
- b) Except as detailed under Article 58, and in accordance with Article 61 of the 2021 FIA Regional Rally Sporting Regulations, competitors may only refuel in the refuel zones designated by the Organisers in the road-book. Other activities inside the refuelling zone are strictly prohibited.

Any breach of these regulations will be reported to the Stewards who may apply penalties at their discretion which may go as far as the disqualification of the crew.

Refuelling procedure (Article 61 of the 2021 FIA Regional Rally Sporting Regulations):

- Only actions inside a refuelling zone directly involved in the refuelling of the competing vehicle are permitted.
- In all refuelling zones, a 5 kph speed limit will apply.
- The responsibility for refuelling is incumbent on the competitor alone.
- It is **MANDATORY** that the relevant personnel, carrying out the refuelling, be wearing clothing which will provide adequate protection against fire.
- Engines must be switched off throughout the refuelling operation.
- It is recommended that the crew remains outside the car during refuelling; however, should they remain inside, their safety belts must be unfastened.

- Solely for the purpose of assisting with the refuelling procedure of their car, two team members of each crew may access this zone.
  - A car may be pushed out of the zone by the crew, officials and/or the two team members without incurring a penalty.
- c) The organisers may make provisions for additional refuelling zones. However, these additional zones shall only be positioned along the itinerary. Except for refuelling rally vehicles, any other kind of servicing is strictly prohibited.

Any breach of the fuel and/or refuelling regulations will be submitted to the Stewards and may result in a penalty, at their discretion, which may go as far as the disqualification.

## 9 - RECONNAISSANCE

### 9.1 - Procedure for registration

- a) Reconnaissance cars must be in conformity with Article 35.1 of the 2021 FIA Regional Rally Sporting Regulations; and must be covered by insurance as required by the traffic laws of Lebanon, no responsibility being imputable to the organisers.
- b) When registering for reconnaissance, one of the crew members must be present to sign an indemnity and register the details of the reconnaissance car (spare recce car, if any), mobile telephone number and contact details of the place of residence.
- c) The Reconnaissance Registration Form can be collected from the Rally Secretariat or downloaded from the A.T.C.L. official website. This form should be filled and sent to the Rally Secretariat before commencing the reconnaissance.

### 9.2 – Reconnaissance Schedule

The road book will be issued on Thursday, June 10<sup>th</sup>, 2021, and will be distributed between 12:00 and 16:00hrs.

The Reconnaissance Schedule starts on Friday, June 11<sup>th</sup>, 2021, at 08:30hrs and ends at 17:00hrs. No Reconnaissance allowed outside these mentioned dates and times.

**Any competitor found in breach of this rule, will be reported to the stewards who may apply penalties at their discretion.**

### 9.3 - Specific and national restrictions – speed limit

- a) In compliance with Article 35.3 of the 2021 FIA Regional Rally Sporting Regulations, reconnaissance is **PROHIBITED** before and after Friday June 11<sup>th</sup>, 2021. If before, or after the aforementioned date any crew and /or competitor is found on any part of any special stage to be used in the rally, they will be reported to the stewards who may apply penalties at their discretion.
- b) Crews will only be permitted to enter and leave special stages through the start and finish controls shown in the Road Book and



may not under any circumstances drive in a direction opposite to that of the rally.

- c) Maximum speed limit of 70 km/h during reconnaissance is imposed on all special stages, unless another speed limit is indicated by traffic signs. In compliance with Article 34.2.2 of the 2021 FIA Regional Rally Sporting Regulations, speeding during reconnaissance will incur a fine applied by the clerk of the course as follows:

- €25 per km per hour over the speed limit

The amount of this fine will be unaltered by any fine imposed by the police.

The fine will be doubled in case of a second offence committed during reconnaissance in the same rally.

- d) Other traffic infringements during reconnaissance will incur a fine applied by the Steward.
- e) All cars must have their headlights on at all times whilst travelling on the special stages.

#### **9.4 - Fitment of speed control checking devices**

It is emphasized that reconnaissance is not a practice run. The competitors must drive in a manner that does not endanger or cause inconvenience to traffic or people living within and near the stages. During reconnaissance, the traffic laws of Lebanon must be strictly complied with as well as the safety and rights of ways of other road users should be respected.

The police may check the speed on the road sections and the special stages using speed check equipment.

#### **9.5 – Compulsory Drivers Briefing**

Drivers briefing will be replaced by “Briefing Notes” when the clerk of the course deems appropriate.

Any breach of the reconnaissance regulations, will result in a penalty at the discretion of the Stewards (Article 12 of the ISC), which may go as far as disqualification. Furthermore, the Stewards may report the competitors concerned to the ASN for possible further sanctions.

## **10 - ADMINISTRATIVE CHECKS**

Drivers and co-drivers are not required to report personally to the administrative checks. Each Competitor may nominate in advance, to the Rally Organiser, one authorised representative to complete administrative checks. Further information will be issued in a bulletin in due time.

### **10.1 - Location**

Administrative checks shall take place on Friday, June 11<sup>th</sup>, 2021 at the:

**Rally Office  
A.T.C.L.; Jounieh.**



## 10.2 - Times / schedule

From 16:30hrs till 20:00hrs, according to an individual time schedule given later in a bulletin or a communication and posted on the official notice board at the Automobile and Touring Club of Lebanon; Jounieh – Lebanon, as well as on the digital notice board.

Crews' representatives reporting outside their time limits for Administrative Checks will be penalised 15. - U.S. \$ per minute to maximum of 15 minutes. Thereafter, they will be reported to the Stewards who may apply penalties at their discretion.

## 10.3 - Documents to be presented

The following items will be checked at Administrative Checks:

- Entrants' licence (if any).
- Drivers' and Co-drivers' competition licences.
- Valid drivers' and Co-drivers' driving licences.
- Rally car documents and registration papers etc...

If the car is not the property of one of the crew members, a letter of authorisation from the owner of the car and/or a power of attorney approving the use of the car should be accompanied along with the entry form.

Letters of authorisation and/or powers of attorney dated more than three months before the date of the rally will not be considered.

- Insurance policy covering the rally vehicle (refer to Art. 5.b of these Supplementary Regulations).
- Motor Sport Personal Accident Insurance (Refer to Art. 5.c, of these Supplementary Regulations).
- Copy of fuel purchase invoice.
- Correctness and completion of all information given on the entry form.
- Authorisation for the drivers by their ASN to take part in the rally should be presented.

Competitors' representatives are required to hold a signed Administrative Clearance Form prior to Scrutineering.

# 11 - SCRUTINEERING, SEALING AND MARKING

The Administrative Check must be completed prior to Scrutineering. Competitors are required to present their signed Administrative Clearance Form prior entering the Scrutineering venue.

1 or max 2 people, duly assigned in writing, for each car, (2 if required to remove underbody protection / 1 person for checking the equipment / 1 person for sealing spare parts) are required for all team entering scrutineering.

## 11.1 - Location

Scrutineering, Sealing and Marking will take place on Friday, June 11<sup>th</sup>, 2021 at the:

## Tennis Courts Venue A.T.C.L.; Jounieh.

### Times / schedule

From 17:00hrs till 20:30hrs, according to an individual time schedule given later in a bulletin or a communication and posted on the official notice board at the Automobile and Touring Club of Lebanon; Jounieh - Lebanon.

Crews' representatives reporting outside their time limits for Scrutineering will be penalized 15. - U.S. \$ per minute to maximum of 15 minutes. Thereafter, they will be reported to the Stewards who may apply penalties at their discretion.

### 11.2 - Windows/Nets

In compliance with the traffic law of Lebanon, **the use of silvered or tinted film is NOT AUTHORISED** on the side as well as the rear windows.

However, and in compliance with Appendix J, Article 253.11, the use of transparent and colourless anti-shatter films on the side windows and the glass sunroof is mandatory.

### 11.3 - Driver's safety equipment

- The control of drivers' helmets and equipment as well as the head restraint (FHR device) will take place at the scrutineering. The helmets must meet one of the standards listed in technical list No. 25 of Appendix J. Each helmet used by the crew will have to be identified and marked during the scrutineering before start. This marking may be checked on the start and/or finish of each special stage.
- In compliance with ISC Appendix L, Chapter III, Article 3, the wearing of an FIA approved Frontal Head Restraint (FHR), homologated according to the FIA 8858 standard, on special stages is **MANDATORY** for all drivers and co-drivers. Homologated FHR systems are listed in the FIA Technical List N° 29.
- In compliance with Appendix L, Chapter III, Article 2, the wearing of overalls as well as gloves (optional for co-drivers), long underwear, a balaclava, socks and shoes homologated to FIA 8856-2000 standard (Technical List N°27) or FIA 8856-2018 standard (Technical List No 74), of Appendix J are **MANDATORY** to be worn on special stages by all drivers and co-drivers.
- Infringements are subject to the penalty of refusal to take the start.
- In compliance with ISC Appendix J, Article 253.8.4, where the occupants' bodies could come into contact with the safety cage, flame retardant protective padding must be provided for protection. All tubes of the cage and all roof reinforcements must be fitted with paddings in compliance with FIA standard 8857-2001 type A; *refer to Technical List No. 23*. Each padding must be fixed in such a way that it is not moveable from the tube.



#### 11.4 – Noise level

In accordance with Appendix J, Article 252-3.6, “all cars used in Rallies ..., the noise level on the open road must not exceed 103 dB(A) for an engine rotation speed of 3500 rpm for petrol engines”.

#### 11.5 - Scrutineering requirements

- Cars must be presented to the scrutineers with the competition numbers, rally plates and optional advertising affixed on the car before entering the Scrutineering venue. Failing to comply with this rule is subject to a cash penalty of 100. - U.S. \$ (Article 6.2.b of these Supplementary Regulations).
- In accordance with Article 31.1.4 of the 2021 FIA Regional Rally Sporting Regulations **the presentation of the car's complete original FIA homologation form at scrutineering is compulsory.** Any breach of these regulations will be reported to the Stewards who may apply penalties at their discretion.
- In accordance with Appendix J, Article 253.6, two belt cutters must be carried on board at all times. They must be easily accessible for the driver and co-driver when seated with their harnesses fastened.
- An authentic copy of the homologation document or certificate, of the rollcage approved by the ASN and signed by qualified technicians representing the manufacturer, must be presented to the event's scrutineers
- In accordance with Article 53.2 of the 2021 FIA Regional Rally Sporting Regulations, each competing car shall carry a red “SOS” sign and on the reverse a green “OK” sign measuring at least 42 cm x 29.7 cm (A3).
- In accordance with Appendix A, Chapter X, Article 5, of the 2021 National Sporting Code, all Competitors, teams and entrants who wish to carry on-board cameras, in-car videos and/or film cameras must have the prior agreement of the Organisers beforehand. **However, it is MANDATORY to provide the Organisers and/or the Clerk of the Course with a copy of the complete unedited recordings upon requisition with no delay.**  
Authorised cameras will be identified by an adhesive decal and must be mounted in/on the car at the time of scrutineering. The mounting of on-board cameras (Interior/Exterior) to be in compliance with Appendix 6 of this Supplementary Regulations.  
The On-Board Camera Application Form can be collected from the Rally Secretariat or downloaded from the ATCL official website. This form should be filled and sent to the Rally Secretariat by Tuesday, June 8<sup>th</sup>, 2021, at 16:30hrs at the latest.  
Failing to observe this rule will be subject to a penalty at the discretion of the Stewards.

## 12 – OTHER PROCEDURES

### 12.1 - Start procedure and order

#### 12.1.1 - Official start

The rally will start on Sunday, June 13<sup>th</sup>, 2021, at 07:00hrs from TC 0 situated in the Casino du Liban; Maameltein.

#### Start area / Start holding area

Competing cars and crews must assemble in the Start Holding Area at the Casino du Liban – Maameltein on Sunday, June 13<sup>th</sup>, 2021 between 06:00 and 06:30hrs.

Failing to comply with this rule will entail a penalty at the discretion of the Stewards.

#### 12.1.2 - Starting order and interval

- a) The starting order will be determined as follows:
  - FIA priority drivers
  - MERC priority drivers
  - Lebanese ASN priority drivers - Rallies
  - Other drivers
- b) All drivers will have an interval of one minute (**1min.**) between their start times.

### 12.2 - Electronic start procedure

The timekeeping in the special stages will be carried out to the 1/10<sup>th</sup> of a second.

In accordance with Article 48.2 of the 2021 FIA Regional Rally Sporting Regulations, the start of the special stages will be carried out by an electronic sequential countdown light system. It will be placed on the left hand side of the road, between 2 and 5 meters ahead of the starting line, counting down by seconds and clearly visible to the crew from the start position.

This system is electronically coupled to a start line detection device that records any situation where a car leaves the start line ahead of the correct signal. The system description is included in Appendix 7 hereafter.

Should the said starting light panel fail to function the start will be given in accordance with Article 48.3 of the 2021 FIA Regional Rally Sporting Regulations.

### 12.3 - Finish procedure

The rally will conclude at the Finish Podium situated in the Casino du Liban – Maameltein on Sunday, June 13<sup>th</sup>, 2021 at 14:30hrs. Competitors shall follow the Officials directions to the finish ramp, directly followed by the final Parc Fermé.

After clearing the finish ramp, the crews shall drive their cars, as instructed by the officials to the final Parc Fermé and/or Final Scrutineering.

However, each crew may nominate a representative, duly assigned by writing, to take delivery of the car out of the final Parc Fermé. In the event that the car is not driveable this shall be reported to the Clerk of the Course



## 12.9 - Responsibility of the Competitor

In accordance with 9.15 of the ISC, the Competitor shall be responsible for all acts or omissions on the part of any person providing any service on their behalf, direct or indirect, including in particular their mechanics, consultants, service providers, as well as any person to whom the Competitor has allowed access to the Reserved Areas. Any breach of this rule will result in a penalty at the discretion of the Stewards

## 13 - IDENTIFICATION OF OFFICIALS

The post chiefs and other officials will be identified as follows:

Senior Rally Officials	White shirts with their names in dark blue letters on their left.
Competitors' Relations Officers	Pink shirts with "C.R.O." in large white letters weaved on their back.
Headquarters staff	Light grey shirts.
Media staff	Light yellow shirts.
Stages Commanders	Blue shirts bearing the A.T.C.L logo on it.
Stages Safety Officers	Navy blue shirts with "SAFETY" weaved on their back.
Stages Time Control Officers	Yellow tabards with "TEAM LEADER" in blue.
Special Stages posts chiefs	Yellow tabards with "TEAM LEADER" in blue.
Stages Doctors	Bright red tabards with "DOCTOR" in black.
Safety Marshals	Bright yellow tabards with "SAFETY" in grey.
Intermediary and Radio Points	Bright yellow tabards with blue radio point symbol.
Red flag marshals	Bright orange tabards with black radio point symbol.
Special Stages Marshals	Blue tabards with "MARSHALS" in white.

## 14 - PRIZES

### 14.1 - Prize-giving:

- a) The prize giving shall take place on the podium at the finish ramp situated in the Casino du Liban – Maameltein on Sunday June 13<sup>th</sup>, 2021 at 14:30hrs.
- b) Competitors that are not personally present during the prize giving ceremony shall lose their right to the prizes they earned. Nevertheless, the classification and attribution of the other prizes won't be modified.



## 14.2 - Prizes:

List of prizes and cups:

- a) General Classification:
  - First 2 Trophies.
  - Second 2 Trophies.
  - Third 2 Trophies.
- b) Class RC2/N4 Cup 2 Trophies (1<sup>st</sup> crew).
- c) Class RC3 Cup 2 Trophies (1<sup>st</sup> crew).
- d) Class RC4 Cup 2 Trophies (1<sup>st</sup> crew).
- e) Class RC5 Cup 2 Trophies (1<sup>st</sup> crew).
- f) Promotion Classification: 2 Trophies (1<sup>st</sup> in Promotion Classification, as per these Supplementary Regulations, Article 4.5).
- g) Junior Drivers/Co-Drivers 2 trophies, 1<sup>st</sup> junior crew in the general Cup classification.
- h) Ladies Cup: 2 Trophies, 1<sup>st</sup> Female Crew.
- i) All finishers: 2 Medals.

The Junior Drivers/Co-Drivers Cup will be awarded to the first junior driver and co-driver in the general classification registered for the 36<sup>th</sup> Spring Rally. In compliance with Chapter II, Article 7, Appendix A of the 2021 National Sporting Code to qualify for this cup, the following conditions will apply:

- The Driver/Co-Driver must have his/her 26<sup>th</sup> birthday after the end of the current year.
- The Driver/Co-Driver must be driving a 2WD cars of class RC3, RC4 and RC5.
- The driver and co-driver may not necessarily be members of the same crew.

## 15 - FINAL CHECKS AND PROTESTS

### 15.1 - Final checks:

The final scrutineering will take place at the Casino du Liban – Maameltein on Sunday June 13<sup>th</sup>, 2021 at 15:00hrs.

Cars subject to final checks (decision by the Stewards) must have one representative present at the final check for the entrant as well as the relevant mechanics, in case of dismantling the whole or parts of the car.

### 15.2 - Protest and Protest Deposits:

- a) In compliance with Article 65.2 of the 2021 FIA Regional Rally Sporting Regulations, all protests must be lodged in writing and handed to the clerk of the course together with the protest deposit of an amount of €1000.-, (*or the equivalent in US dollars at the rate of the day*). This protest deposit shall not be returned if the protest is judged unfounded.



---

If the protest requires the dismantling and the re-assembly of different part of a car, the claimant must pay an additional deposit:

- i. If the protest involves a clearly defined part of the car (engine, transmission, steering, braking system, electrical installation, bodywork, etc.): **USD 2,000** per each.
  - ii. Protests involving the whole vehicle are inadmissible.
- b) The expenses incurred by the work and by the transport of the vehicle shall be borne by the claimant if the protest is unfounded, or by the competitor against whom the protest is lodged if the claim is founded.
- c) If the claim is unfounded, and if the expenses incurred by the protest (scrutineering, transport etc.) are higher than the guarantee deposit, the difference shall be borne by the claimant.

Conversely, if the expenses are less, the difference shall be returned to him.

### **15.3 - Appeal deposit:**

- a) The sum of the National appeal deposit (ASN): **USD4,000**

## APPENDIX 1 ITINERARY OF THE RALLY

Version (3), 14/05/2021

<b>LEG 1</b>							<b>Sunday, June 13<sup>th</sup>, 2021</b>
TC	LOCATION	SS dist.	Liaison dist.	Total dist.	Target time	First car due	
0	Start - Casino du Liban	-	-	-	-	07:00	<b>Section 1</b>
1	Blat	-	17.85	17.85	00:31	07:31	
<i>SS1</i>	<i>BLAT 1</i>	<i>17.36</i>	-	-	-	<i>07:34</i>	
2	Monsef	-	27.86	45.22	00:54	08:28	
<i>SS2</i>	<i>MONSEF 1</i>	<i>14.63</i>	-	-	-	<i>08:31</i>	
2A	Regrouping & Technical Zone <b>IN</b>	-	35.37	50.00	01:05	09:36	
2B	Regrouping <b>OUT</b> / Service <b>IN</b>	-	-	-	00:13	09:49	<b>Section 2</b>
<b>Service A - Adma (LBCI parking)</b>		<b>31.99</b>	<b>81.08</b>	<b>113.07</b>	<b>00:45</b>		
2C	Service <b>OUT</b>	-	-	-	-	10:34	
<b>RZ</b>	<b>Refuel - Adma (LBCI parking)</b>	<b>31.99</b>	<b>81.08</b>	<b>113.07</b>			
<b>1</b>	<b>Distance to FINISH</b>	<b>34.69</b>	<b>84.51</b>	<b>119.20</b>			
3	Ghazir, Maameltein	-	4.16	4.16	00:15	10:49	
<i>SS3</i>	<i>CASINO DU LIBAN 1</i>	<i>1.35</i>	-	-	-	<i>10:52</i>	
4	Blat	-	17.83	19.18	00:35	11:27	
<i>SS4</i>	<i>BLAT 2</i>	<i>17.36</i>	-	-	-	<i>11:30</i>	
5	Monsef	-	27.86	45.22	00:54	12:24	
<i>SS5</i>	<i>MONSEF 2</i>	<i>14.63</i>	-	-	-	<i>12:27</i>	
5A	Regrouping & Technical Zone <b>IN</b>	-	34.52	49.15	01:05	13:32	<b>Section 3</b>
<b>Regrouping Maameltein, Ghazir,</b>		<b>33.34</b>	<b>84.37</b>	<b>117.71</b>	<b>00:13</b>		
6	Ghazir, Maameltein	-	-	-	-	13:45	
<i>SS6</i>	<i>CASINO DU LIBAN</i>	<i>1.35</i>	-	-	-	<i>13:48</i>	
6A	Finish Holding Area	-	0.14	1.49	00:05	13:53	
	<b>Finish Podium - Casino du Liban</b>	-	-	-	-	14:30	
<b>Casino du Liban</b>		<b>1.35</b>	<b>0.14</b>	<b>1.49</b>			
<b>SUNDAY TOTALS</b>		<b>66.68</b>	<b>165.59</b>	<b>232.27</b>			

Sunday, June 13<sup>th</sup>, 2021

Dawn: 03:59hrs.

Sunrise: 05:36hrs.

Sunset: 19:33hrs.

Version (3), 14/05/2021

<b>TOTALS OF THE RALLY</b>						
		SS	Liaison	Total		%
Sunday, June 13 <sup>th</sup> , 2021	Section 1	31.99	81.08	113.07	<i>% of</i>	28.29%
Sunday, June 13 <sup>th</sup> , 2021	Section 2	33.34	84.37	117.71	<i>Special</i>	28.32%
Sunday, June 13 <sup>th</sup> , 2021	Section 3	1.35	0.14	1.49	<i>Stages</i>	90.60%
<b>TOTAL - 6 Special Stages</b>		<b>66.68</b>	<b>165.59</b>	<b>232.27</b>		<b>28.71%</b>

---

## **APPENDIX 2:**

### **RECONNAISSANCE SCHEDULE**

# **ALL COMPETITORS**

**Starts: Friday, June 11<sup>th</sup>, 2021 at 08:30hrs**

**Ends: Friday, June 11<sup>th</sup>, 2021 at 17:00hrs**

**SS 1 / 4 BLAT**

**SS 2 / 5 MONSEF**

**SS 3 / 6 CASINO DU LIBAN**

## **APPENDIX 3**

### **COMPETITORS' RELATIONS OFFICER**

The Competitors' Relations Officer is:



**Michael Schucry**

The Competitors' Relations Officer will be easily identified by his Pink shirt with "C.R.O." in white letters weaved on his right.

#### **PRESENCE DURING THE RALLY:**

When the Secretariat is opened, a planning of the places and schedule where he will be on duties will be established. This planning will be post on the Official Notice Board and will include:

- Presence at Documentation and Scrutineering
- At the Secretariat of the Meeting.
- At the Start of the Rally.
- At the Regrouping halts.
- At the Service Parks.
- Near the Parc Fermé(s) and the Finish (the latter being dependent on the rally timetable).

#### **FUNCTION:**

The principal duty of the CRO is to provide information or clarifications in connection with the regulations

#### **MEDIATION:**

- Avoid forwarding questions to the stewards which could be solved satisfactorily by a clear explanation with the exception of protests (for example, clarify disputes over times, with the assistance of the time-keepers).
- The Competitor's Relations Officer shall refrain from saying anything or taking any action which might give rise to protests.

## **APPENDIX 4**

### **IDENTIFICATION NUMBERS, ADVERTISING AND NAMES**

#### **Identification Numbers and Compulsory Advertising:**

- 1 2 x Door Panel with Competition Number 67x17cm. The top of the plate shall be placed between 7 cm and 10 cm below the bottom window line. No other signage shall be placed within 10 cm of the plate. (1)

**(Roof Panel (2) not applicable during the 36<sup>th</sup> Spring Rally)**

- 2 Rear window panel measuring 30x10cm shall be positioned at the bottom of the rear window in a central location. An adjacent area of 15x15cm shall contain a fluorescent orange (PMS 804) 14cm high competition number on a clear background. The number must be visible from the rear at eye level. (3)
- 3 Front rally plate 43x21.5cm. (4)
- 4 Rear side windows: (5)  
2 x Competition Number 20 cm high with a stroke width of 25 mm coloured in fluorescent orange (PMS 804) shall be placed on the rear side windows adjacent to the crew's name.

The name of the driver with his/her passport nationality national flag must appear on the rear side window of both sides of the car (under the Competition Numbers). The Surname alone shall be:

- 5.1 In Helvetica upper case for the first letter of the name and the remainder in lower case
- 5.2 In white on a clear background.
- 5.3 To a height of 6cm. and a stroke width of 1.0cm.

#### **Organisers' Optional Advertising:**

- 1 A 10cm. high strip on the upper part of the windscreen, according to Article 16.7 of the 2021 International Sporting Code (6).
- 2 One space on each Front Door of the vehicle (67cm x 17cm) situated 10cms beneath the Door Panel (7).

A FURTHER BULLETIN WILL DETERMINE THE ADVERTISING BRANDS.

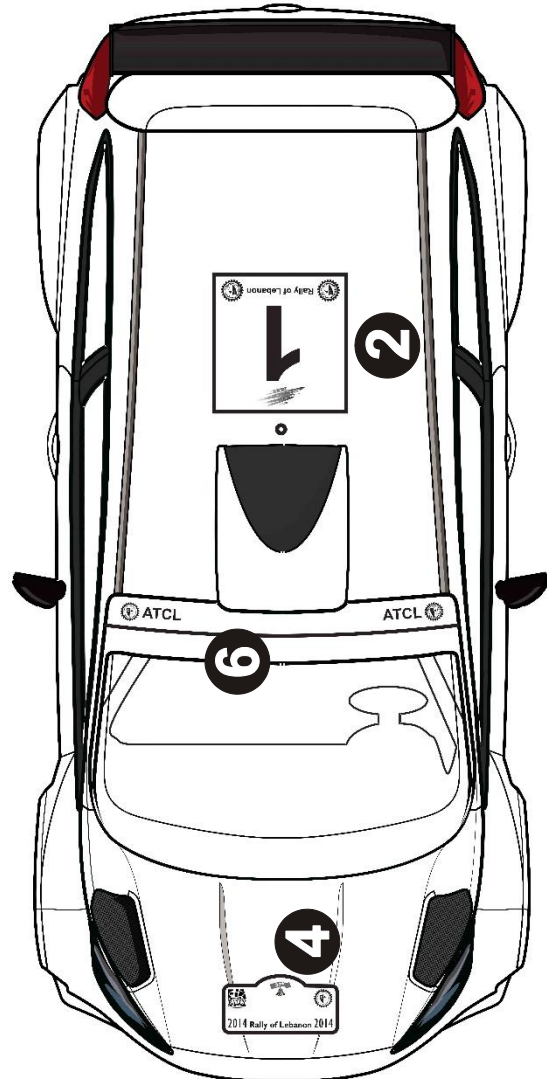
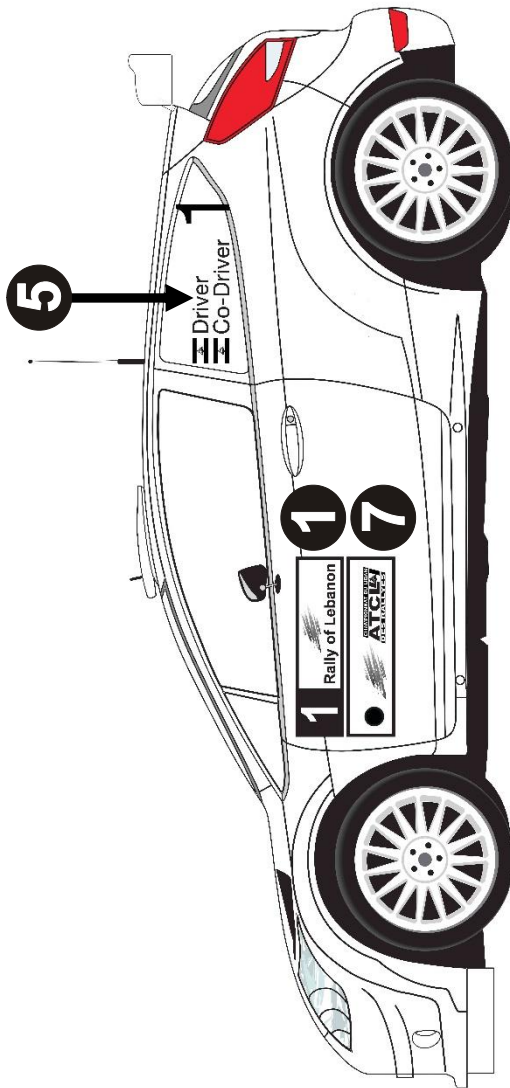
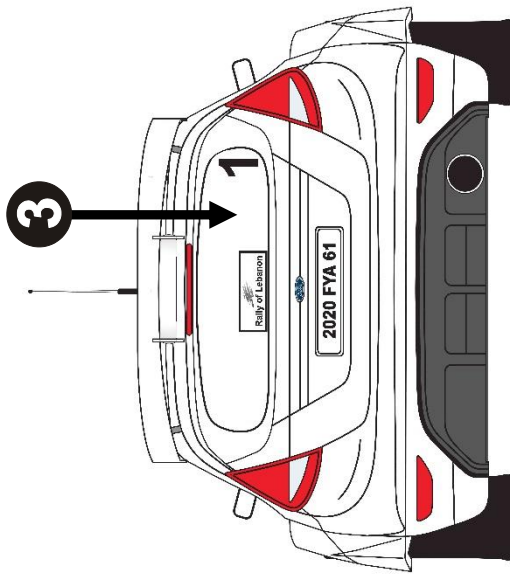

## **APPENDIX 5**

### **EXTRACTS FROM FIA APPENDIX L**

#### **1. Helmets (Appendix L, Chapter III, Art. 1)**

All drivers must wear crash helmets which meet one of the standards listed in FIA Technical List N° 25.

When the use of an FHR, according to Article 3 below, is mandatory, only helmets homologated to one of the following FIA standards are authorised:

- 8858-2002 or 8858-2010 (Technical List N°41),
- 8859 (Technical List N°49),
- 8860-2004 or 8860-2010 (Technical List N°33),
- 8860-2018 or 8860-2018-ABP (Technical List N°69)

#### **2. Flame-resistant clothing (Appendix L, Chapter III, Art. 2)**

On special stages of rallies, all drivers and co-drivers must wear overalls as well as gloves (optional for co-drivers), long underwear, a balaclava, socks and shoes homologated to the FIA 8856-2000 standard (*Technical List N°27*) or FIA 8856-2018 standard (*Technical List No 74*).

Users must ensure that garments are not too tight, as this reduces the level of protection.

Embroidery sewn directly onto the overalls shall be stitched onto the outermost layer only, for better heat insulation. Backing material of badges and thread used for affixing them to the overalls must be flameproof. The stitching of badges can go through all the layers, provided that the thread is flameproof and compliant with ISO 15025.

Printing or transfers on drivers' clothing must be carried out only by the manufacturer of the product and must not reduce the performance of the suit as defined in the 8856-2000 or 8856-2018 standard. (see Appendix 1 of the FIA 8856-2000 Standard or Appendix F of the FIA 8856-2018 Standard for detailed requirements and instructions for use). Any FIA-approved 8856-2018 garment customised using printing or transfers must be accompanied by a certificate from the manufacturer.

#### **Biometric Devices (Appendix L, Chapter III, Art. 2.1)**

Drivers may wear a device to collect biometric data during racing.

- If the biometric device is integrated into a protective garment homologated to FIA Standard 8856, the garment shall be homologated to FIA Standards 8856 and 8868-2018.
- If the biometric device is a stand-alone device, then the device must be homologated to FIA Standard 8868-2018 only. This device must be worn in addition to the garment homologated to FIA Standard 8856.

#### **3. Frontal Head Restraint (FHR, Appendix L, Chapter III, Art. 3)**

The wearing of any device intended to protect the head or neck and attached to the helmet is prohibited, unless the device has been homologated according to the FIA



8858 standard. Homologated FHR systems are listed in the FIA Technical List N° 29.

The minimum reclined HANS collar angle shall be 60° from the horizontal.

Any padding used between the driver and the HANS® yoke must not be more than 15 mm thick when the driver is seated in the car fully equipped with the harness tightened. The padding must be covered by a flameproof material in conformity with the standard ISO 15025 and the padding must not be wider than 8 mm on each side of the HANS® yoke.

FHR systems must be worn only with FIA-approved items according to the following chart:

<b>Helmet</b>	<b>Tether system (tether, tether end fitting and helmet anchorage)</b>
FIA 8860 (Technical List N°33 & 69) FIA 8858 (Technical List N°41) FIA 8859 (Technical List N°49)	FIA 8858 (Technical List N°29)

For more details when the device used is the HANS®, the “Guide for the Use of HANS® in international motor sport”, published by the FIA Institute for Motor Sport Safety, can be found on [www.fia.com](http://www.fia.com), under the heading FIA Sport - Regulations - Drivers’ Equipment.

#### **4. Safety Belts**

Drivers must be properly restrained in their seat by safety belts in conformity with for the vehicle concerned, at all times during when it is mobile on a circuit, pit lane, special stage or competition course.

Drivers must be properly restrained in their seat by safety belts in conformity with the technical regulations for the vehicle concerned, at all times during a competition when it is mobile on a circuit, pit lane, special stage or competition course.

#### **5. Wearing of jewellery (Appendix L, Chapter III, Art. 5)**

The wearing of jewellery in the form of body piercing or metal neck chains is prohibited during the competition and may therefore be checked before the start.

## APPENDIX 6

### MOUNTING OF ON-BOARD CAMERAS

#### 1- INTERIOR MOUNT

The mounting should be of a rigid type, placed in the centre behind the back of the seats.

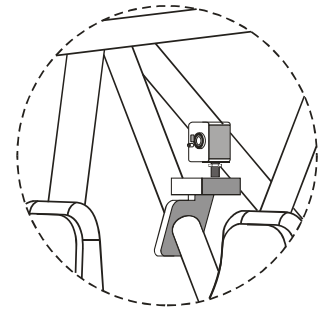
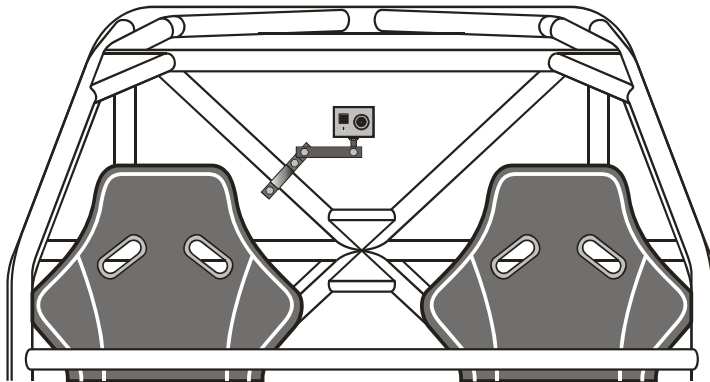

**Handlebar Mount**



For pencil type cameras, they can be mounted on the front rollbar/windscreen pillar, the control unit should be fixed on the floor pan behind the seats. (Similar to battery fixation)

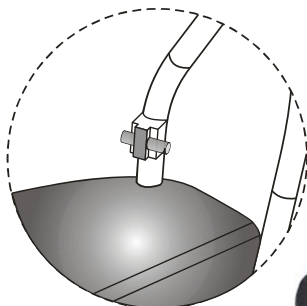

On front Rollbar

OR

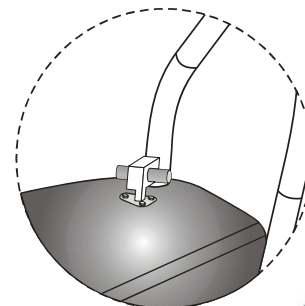

On dashboard



#### 2- EXTERIOR MOUNT

A support bracket of 40mm. fixed by screws with a reinforcement plate of minimum 3mm thick and a surface of 120 cm<sup>2</sup> should be used

**IMPORTANT: The reinforcement plate should be placed from inside the body work in order to reinforce the support area.**

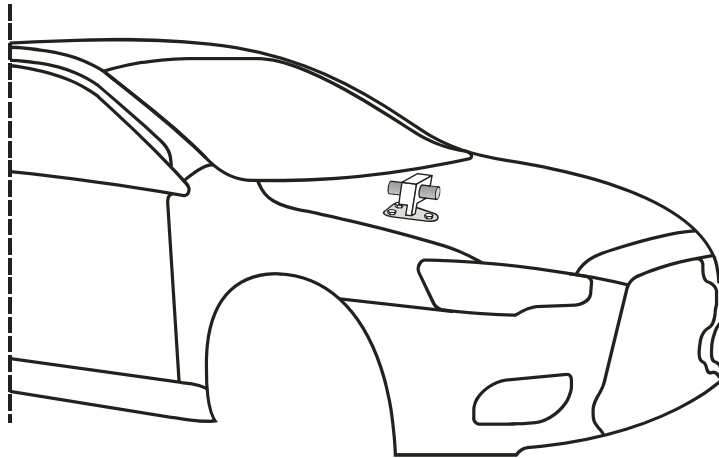

### 3- PROHIBITED MOUNTINGS



## APPENDIX 7

### START LIGHT SEQUENCE

In accordance with Article 48.2 of the 2021 FIA Regional Rally Sporting Regulations The start of the special stages will be carried out by an electronic sequential countdown light system as described in the here below figure.

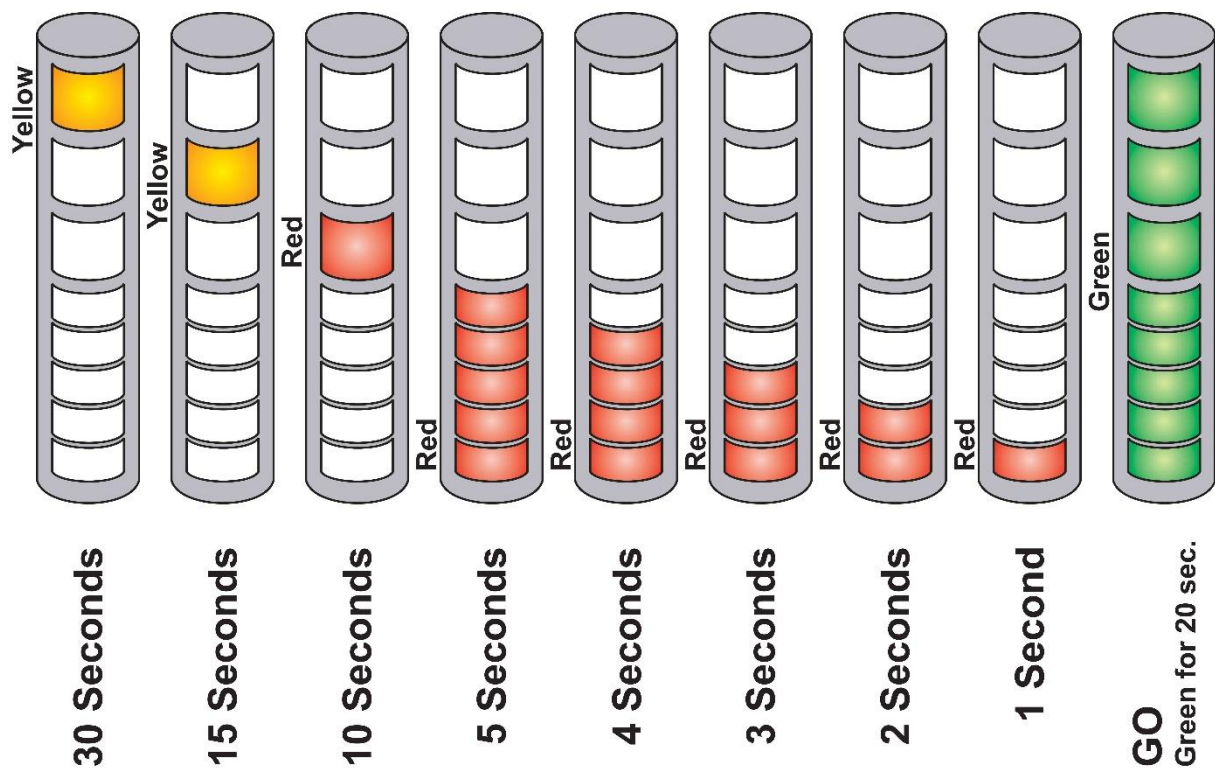



---

**This page has been left blank intentionally.**