

APPENDIX C

Article 1: General:

Eligible cars for each type of event:

1- Rallies:

a) Homologated Vehicles

The eligible vehicles to participate in rallies are as follows:

All vehicles classes described in Article 4.2 of the 2018 FIA Regional Rallies Championships Sporting Regulations, excluding RGT class cars. The concerned cars must be in conformity with Appendix J of the F.I.A International Sporting Code for the running year. Refer to table below:

Classes and Groups:

Classes	Groups
RC2/-N4	S2000-Rally: 1.6 T engine with a 28mm restrictor
	S2000-Rally: 2.0 Atmospheric
	Group R5 (VR5) Group R4 (VR4) (not eligible in Europe)
RC2/N4	Group N car over 2000cc (current N4)
RGT	* RGT cars are excluded
RC3	Group A car over 1600cc and up to 2000cc
	Super 1600
	R2 (atmo over 1600cc and up to 2000cc – VR2C and turbo over 1067cc and up to 1333cc – VR2C)
	R3 (atmo / over 1600cc and up to 2000cc – VR3C and turbo over 1067cc and up to 1333cc – VR3C)
	R3 (turbo / up to 1620cc / nominal – VR3T) R3 (diesel / up to 2000cc / nominal – VR3D)
RC4	Group A up to 1600cc
	R2 (atmo over 1390cc and up to 1600cc – VR2B and turbo over 927cc and up to 1067cc – VR2B)
	Kit-car up to 1600cc
	Group N car over 1600cc and up to 2000cc
RC5	Group N car up to 1600cc
	R1 (atmo up to 1600cc - VR1A/VR1B and turbo up to 1067cc - VR1A/VR1B)

- **An FIA technical passport is mandatory for S2000, R5, and Super 1600.**
- **The complete original FIA homologation form and other necessary certifications must always be available.**

b) Vehicles with Expired Homologations

- i. Cars whose homologations have expired, and still accepted by the FIA, up to a maximum of four years before the beginning of the current year, *i.e. Jan 1st 2014 up to Dec 31st 2017.*
- ii. National Cars according to Article 4.4 of the 2018 FIA Regional Rallies Championship Sporting Regulations whose homologations have expired between five and **ten** years before the beginning of the current year, *i.e. Jan 1st 2008 up to Dec 31st 2013.*
- iii. FIA Rally touring cars with extended eligibility for regional rallies; (*refer to fia.com*).
- iv. It is **MANDATORY** for these vehicles within this category to be in conformity with their expired homologation forms.

2- Hill-Climbs:

The eligible vehicles to participate in hill-climbs are:

- a) All vehicles classes described in Article 4.2 of the 2018 FIA Regional Rallies Championships Sporting Regulations, **excluding RGT class cars**; *Refer to Article 1.a above.* The vehicles concerned must be in conformity with Appendix J of the F.I.A International Sporting Code for the running year.

Group A8. The vehicles concerned must be in conformity with Appendix J of the F.I.A International Sporting Code for the running year

- i. Cars whose homologations have expired, and still accepted by the FIA, up to a maximum of four years before the beginning of the current year, *i.e. Jan 1st 2014 up to Dec 31st 2017.*
 - ii. National Cars according to Article 4.4 of the 2018 FIA Regional Rallies Championship Sporting Regulations whose homologations have expired between five and **ten** years before the beginning of the current year, *i.e. Jan 1st 2008 up to Dec 31st 2013.*
 - iii. FIA Rally touring cars with extended eligibility for regional rallies; (*refer to the attached table*).
 - iv. It is **MANDATORY** for these vehicles within this category to be in conformity with their expired homologation forms and the current FIA safety regulations.
- b) Group SM must be in conformity with Appendix C of the ASN National Sporting Code for the year 2018 (*find here below*).

Vehicles groups SM classes are as follows:

SM1	Up to 1400 cm ³
SM2	Over 1400 cm ³ and up to 1600 cm ³
SM3	Over 1600 cm ³ and up to 2000 cm ³
SM4	Over 2000 cm ³ and up to 3000 cm ³
SM5-2	Over 3000 cm ³ and up to 3500 cm ³ – 2WD
SM5-4	Over 3000 cm ³ and up to 3500 cm ³ – 4WD
SM6	Over 3500 cm ³ and up to 4500 cm ³

3- Speed Test:

- a) All vehicles classes described in Article 4.2 of the 2018 FIA Regional Rallies Championships Sporting Regulations, Refer to Article 1.a above. The vehicles concerned must be in conformity with Appendix J of the F.I.A International Sporting

Code for the running year. For vehicles with expired homologations refer to Article 1.b above.

- b) Group SM must in conformity with Appendix C of the ASN National Sporting Code for the year 2018. *Refer to Article 2.b above.*
- c) Group L for Amateur Series as well as Super Series must be in conformity with Appendix C of the ASN National Sporting Code for the year 2018.

4- Cross Country:

- a) Group T1: Modified cross country vehicles.
- b) Group T2: Series cross country vehicles.
- c) Group T4: Trucks.
- d) Rally Cars.
- e) UTV.

Refer to Appendix A of the National Sporting Regulations.

Article 2: Homologation:

Is the official certification made by the FIA that a minimum number of cars of a specific model have been made on series-production terms to justify their classifications.

Application for homologation shall be submitted to the FIA by the ASN of the country in which the vehicle is manufactured and shall entail the drawing up of a homologation form.

It must be established in accordance with the special regulations called "Regulations for homologation", laid down by the FIA.

Homologation of a series-produced car will become null and void four years after the date on which the series-production of the said model has been stopped (series-production under 10 % of the minimum production of the group considered).

The homologation of a model can only be valid in one group, such as, Production Cars (Group N)/Touring Cars (Group A)/Series Cross-Country Cars (Group **T2**).

Nevertheless, Conformity guidelines along with Technical definitions and/or details are herewith enclosed:

Important Guidelines for the Year 2018

- With the presented car, the crew should present all overalls as well as gloves (optional for co-drivers), long underwear, balaclava, socks and shoes homologated to the FIA 8856-2000 standard.
- SEAT BELTS: FIA STANDARD.
Wearing of two shoulder straps and one lap strap; anchorage points on the shell: two for the lap strap, two or possibly one symmetrical about the seat for the shoulder straps. These belts must be homologated by the FIA and comply with FIA standard n° 8853/98
MODIFICATIONS APPLICABLE AS FROM 01.01.2018
Harnesses in compliance with FIA 8853-2016 standard
Compulsory as from 01.01.2018 for the following cars:
 - Super 2000 (Rallies) cars in compliance with Art. 255A of 2013 Appendix J.
 - Group R5 cars in compliance with Art. 261 of Appendix J.
- For rallies, two belt cutters must be carried on board at all times. They must be easily accessible for the driver and co-driver when seated with their harnesses fastened.

Examples:

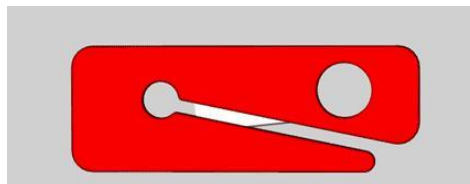

- In accordance with Appendix J, Article 252-3.6, “all cars competing in Rallies ..., the noise level on the open road must not exceed 103 dB(A) for an engine rotation speed of 3500 rpm for petrol engines”.
- For rallies, each competing car shall carry a red “SOS” sign and on the reverse a green “OK” sign measuring at least 42 cm x 29.7 cm (A3).
- The use of the Head Restraint System (Hans[®] device) is MANDATORY for all motorsports events in the National Sporting Calendar excepting Speed Test events.
- Fire extinguishers (Appendix J, Article 253.7):
The system must be used in accordance with the manufacturer's instructions and with Technical Lists n° 16 or n° 52.
In rallies, the minimum quantity of extinguishant for systems of Technical List n° 16 must be 3 kg.

- Steering (Appendix J, Article 253.4):
The locking system of the anti-theft steering lock may be rendered inoperative. The column adjusting system must be locked and must be operated only with tools.
- Safety Cages:
 - In accordance with Appendix J, Article 253.8.1, inside the cockpit, the passage of the following elements between the side members of the bodyshell and the safety cage is forbidden:
 - Electric cables
 - Lines carrying fluids (except windscreen washer fluid)
 - Lines of the extinguishing system.
 Members may intrude into the occupant's space in passing through the dashboard and trims.
Application: For all categories including SM vehicles.
 - Locally built safety cages are **PROHIBITED**.
Application: Rallies and hill-climbs.
 - Protective Padding:
Where the occupants' bodies could come into contact with the safety cage, flame retardant padding must be provided for protection.
All tubes of the cage identified on Drawing 253-68 and all roof reinforcements must be fitted with paddings in compliance with FIA standard 8857-2001 type A (see Technical List n° 23). Each padding must be fixed in such a way that it is not moveable from the tube.
Application: For all categories including SM vehicles.
For competitions without co-driver, paddings are compulsory on driver's side only.
- Helmets (Technical list 25):
Helmets following the standard BS6658-85 Type A/FR are NOT VALID, however they can still be used in Speed Test events ONLY.
- Tyres for rallies 2018
For all rally events the list of homologated tyres MANDATORY to be used is available on the FIA website, under the Regulations section: 2018 List of eligible asphalt tyres for FIA Rallies, under the following link:
<http://www.fia.com/regulation/category/117>
- TURBOS.
 - a) The restrictor for all Classes and Groups, with valid or expired homologations, should be in conformity with Appendix J of the International Sporting Code for the running year.
 - b) Turbo Sealing
Turbo must be ready to seal (wire + holes). The sealing will be done according to the here below.
 - i. The maximum distance between fixed points (bolts and/or casting) and first aluminium seal should be 20mm.

- ii. Sealing of turbocompressors: All parts of the turbo must be sealed together / All the air necessary for feeding the engine must pass through the restrictor

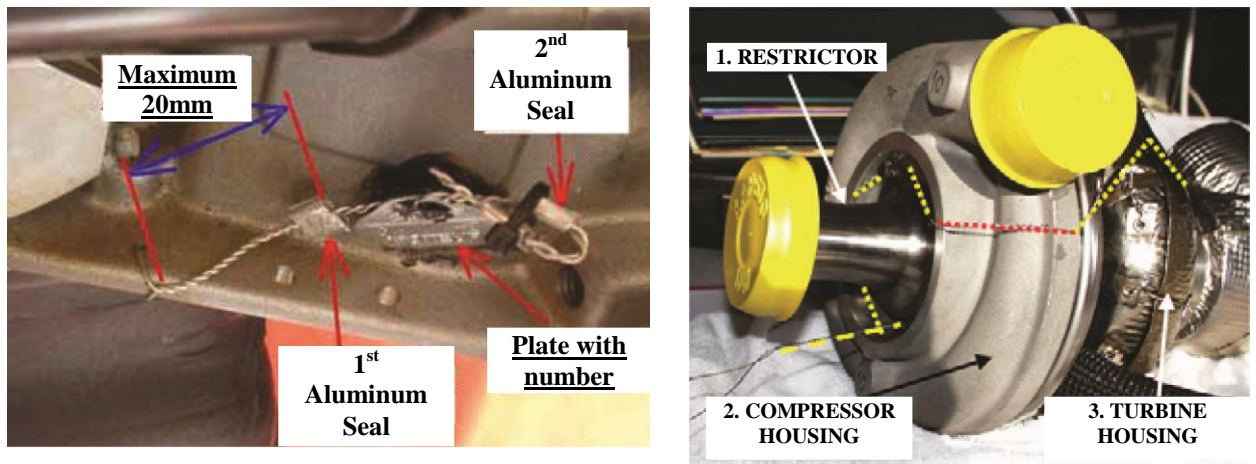

CORRECT RESTRICTOR SEALING



WRONG RESTRICTOR SEALING

All spare parts and tools must be fixed either behind the driver's and/or co-driver's seats or underneath the driver's and/or co-driver's seats.

- RN4 Cars with corrected cylinder capacity greater than 2-litres participating in hill-climbs in addition to rallies should be in conformity with the 2018 Appendix J, Article 254-7.
- TV RIGHTS – ON BOARD CAMERAS
 - a) In accordance with Chapter I, Article 4 of the Internal Regulations, “All filming and moving picture rights pertaining to any Lebanese Motor Sports Championship shall be vested in the ASN. Without the written agreement of the ASN, no organisation, commercial company or brand may be associated with a Lebanese Motor Sport Championship, Trophy, Cup, Competition or Challenge. The same applies to all forms of moving pictures of a Lebanese Motor Sport Championship, Trophy, Cup or Challenge”.

- b) The mounting(s) and the presence of camera(s) in the driver/codriver's compartment is authorised only between the vertical transverse plane through the rearmost point of the dashboard (in relation to the vehicle's displacement direction) and the vertical transverse plane of the rearmost point of the driver/codriver's seats (in relation to the vehicle's displacement direction).

Only mountings attached by screws, metal screw clamps, quick clamping collars and metallic inserts are permitted (no bonding, double-sided tape, adhesive material, suction devices, etc.). (*refer to Appendix I hereafter*).

It is forbidden to mount cameras on the outside of the car or for them to protrude beyond the bodywork.

All camera positions and mountings used must be shown and approved during scrutineering before the start of the competition.

• **PENALTIES:**

Any competitor presenting to scrutineering not fulfilling all the requirements will be fined according to the list hereafter.

Scale of penalties

1. 50.- U.S. \$ PER ITEM
 - Empty fire extinguishers.
 - Inappropriate battery terminal protection and / or fixation.
 - Improper installation of fuel lines.
 - Towing eyes with improper indicating colors.
 - Lack of Driver or co-driver equipment. *i.e., Underwear, overalls, helmets, gloves (for driver) balaclava, socks, shoes as well as belt cutters and Head Restraint System (Hans® device).*
2. 100.- U.S. \$ PER ITEM
 - Turbo seals, the vehicles presented to scrutinizing must be wired and ready according to technical requirements. Any breach of this rule will result in imposing the abovementioned fee.
 - Late scrutineering.
 - Re-Scrutineering.
3. REFUSAL TO START THE EVENT
 - The absence of the vehicle AUTHENTIC homologation documents and its appendices (on FIA official paper).
 - The absence of the rollcage AUTHENTIC certificate.
4. AT THE DISCRETION OF THE STEWARDS:
 - All other missing items.
 - Other conditions not fulfilled.

SAFETY ITEMS:

Description	Appendix J	FIA Standard	Technical list
Safety harnesses	Art. 253-6	8853/98 & 8854/98	24
Fire Extinguishers	Art 253-7		16 or 52 Extinguishers must not be more than 2 years after either the date of filling or the last check or corresponding expiry date.
Roll-cage	Art. 253-8		Homologated or Certified by an ASN according to the FIA homologation regulations for safety cages. The original certificate must be presented to the event scrutineers.
Protective padding	Art 253-8.2.2.6		23
Windows	Art 253-11		(Refer to Supplementary Regulations). Windshield must be of laminated glass. The use of transparent & colorless anti shatter films on side & rear windows is mandatory. Silver or tinted films are prohibited according to Lebanese traffic regulations.
Fuel Tanks & Connections	Art 253-14	FT3-1999	14 No bladder should be used more than 5 years after the date of manufacture.
Seats	Art 253-16	8855-1999	12 The limit of use is 5 years from the date of manufacturing as indicated on the mandatory label.
		8862-2009	40 The limit of use is 10 years from the date of manufacturing as indicated on the mandatory label.

DRIVERS' EQUIPMENT:

Description	Appendix J	FIA Standard	Technical list
Helmets	Chap III 3.1	8860-2004	25
Advanced Helmets	Chap III 3.1	8859-2016	49

Overall under garments Socks balaclava boots	Chap III 3.2	8856-2000	27
Frontal Head Restraint System	Chap III 3.1	8858-2002 and 8858-2010	29

Head Restraint System (Hans[®] device) is MANDATORY for all Rallies and Hill-Climb in the National Sporting Calendar as well as all International and MERC events. (Refer to appropriate article here-before.)

TECHNICAL REGULATIONS FOR GROUP SM CARS

Article 1- Definition:

All production cars, being homologated Touring, Grand Touring, etc,... and/or with expired homologations or cars comparable to Category I, refer to Appendix J Article 251-1-1 and 277 of the International Sporting Code, are eligible to compete in this group for hill-climb events only.

Article 2- General remarks:

- All modifications are forbidden unless expressly authorized by the present regulation specific to this group.
- The cars in this group, for safety reasons, must comply with the following articles of Appendix J of the International Sporting Code:

Battery / Electrical System	255-8.1 255-8.2 & 255-8.3
Braking safety:	253-4
Additional fasteners	253-5
Safety fixing device for windshield	253-12
Circuit breaker:	253-13
Safety tank:	253-14
Fuel pipes, pumps and filters:	253-3
Openings for refuelling and caps:	259-6.2
Electric cables:	283-3.1
Safety belts:	253-6
Extinguishers:	253-7.1 & 253-7.2
Rear view mirrors:	253-9
Towing eye:	253-10
Firewall:	253-15
Seats:	253-16
Safety structures (roll cage):	253-8
- In addition to Appendix J, Article 253-8,
 - i. All Group SM vehicles which are not and/or have not been homologated by the FIA should have their roll-cage structure according to the here above mentioned article and related drawings taking into consideration the first model year production of the vehicle similar to the “start of homologation date” of the FIA.
 - ii. For FIA current or expired homologated vehicles competing in Group SM, Article 253-8 is fully applicable.
 - iii. Locally built safety cages are **PROHIBITED**.
 - iv. In accordance with Appendix J, Article 253.8.1, inside the cockpit, the passage of the following elements between the side members of the bodyshell and the safety cage is forbidden:
 - Electric cables
 - Lines carrying fluids (except windscreen washer fluid)
 - Lines of the extinguishing system.
 Members may intrude into the occupant's space in passing through the dashboard and trims.
 - v. For twin-volume cars with a fuel tank installed in the luggage compartment, a fireproof and liquid-proof case must surround the fuel tank and its filler holes. For three-volume cars, a fireproof and liquid-

proof bulkhead must separate the cockpit from the fuel tank. Nevertheless, it is recommended that this liquid-proof bulkhead be replaced by a liquid-proof case as for twin-volume cars.

- vi. An efficient protective screen must be placed between the engine and the occupant's seat, in order to prevent the direct passage of flames in case of fire. Should this screen be formed by the rear seats, it is advisable to cover them with a flameproof coating.
- Any vehicle which is judged to be dangerous may be excluded from the event by the stewards.
- All modifications are forbidden unless expressly authorized by this regulation.
- The components of the car must retain their original function.

Article 3:

3.1- Weight:

Cars are subject to the following scale of minimum weight in relation to their cubic capacity:

a. Up to and including 1400cc	690 Kg.
b. Over 1400cc and up to and including 1600cc	770 Kg.
c. Over 1600cc and up to and including 2000cc	850 Kg.
d. Over 2000cc and up to and including 3000cc	980 Kg.
e. Over 3000cc and up to and including 3500cc	1100 Kg.
f. Over 3500cc and up to and including 4500cc	1300 Kg.

- The use of ballast is permitted to complete the weight of the car, in the conditions provided for under the article 252.2.2 appendix J. However, if the initial weight of a certain vehicle, given by the original manufacturer is lower than the one defined above, this weight should be considered as minimum. This exception is valid only if the original engine & gearbox are used.
- In case of supercharging, the nominal cylinder-capacity will be multiplied by 1.7 for petrol engines and by 1.5 for diesel engine, and the car will pass into the class corresponding to the fictive volume thus obtained. The car will be treated in all respects as if its cylinder-capacity thus increased were its real capacity.

3.2- Ground clearance:

No part of the car must touch the ground when all tyres on one side are deflated. The test shall be carried out on a flat surface under race conditions (occupants on board).

Article 4- Modifications and general conditions:

4.1 Engine:

Only engines from same vehicle manufacturer are allowed.

Maximum capacity allowed is 4500 cc

The engine and its internals are free, but the original location and mounting direction have to remain the same.

The mountings are free, provided that the angle and the position of the engine in its compartment are not modified. Supports may be welded to the engine and to the bodywork and their position is free.

4.2 Cylinder Head: Valves, number of valves and camshafts are free.

4.3 Supercharging:

Supercharging of any kind is prohibited unless the vehicle is/was originally equipped with such a device by the original manufacturer and/or his official tuner(s).

The original supercharging system should be maintained, *i.e. no twin turbo and/or superchargers are allowed unless originally fit.*

4.4 Limitations: All vehicles with supercharged engines must be fitted with a restrictor of maximum 38mm, (according to the drawing 254-4 of the appendix J). The external diameter of the restrictor at its narrowest point must be less than 44mm and must be maintained over a distance of 5mm to each side.. For cars with twin turbo engines, each device should be fitted with a restrictor of maximum 24mm.

4.5 Ignition System: Free.

4.6 Fuel System: Fuel pumps carburetors, injectors and metering systems are free.

4.7 Air feed: Air filters, plenums as well as the boxes are free.

4.8 Lubrication: Radiator exchangers oil/water sump pump (dry sump) strainers lines are free without modifying the body.

4.9 Exhaust System: The system is free, but pipe outlets must be directed either rearwards or sideways, if the exhaust pipes are directed rearwards their outlets shall be situated between 100mm and 450mm. above ground level. If the exhaust pipes are directed sideways their outlets must be located to the rear of a vertical plane passing through the wheelbase center plane and may not be projected beyond the bodywork in anyway and opposite to the fuel tank filling cap and breather.

4.10 Cooling System: Free.

4.11 Oil Catch Tank: If a car has a lubrication system that includes an open type sump breather, this sump breather must vent into a catch tank as per the following

- | | |
|-----------------|-------------------|
| a. Up to 2000cc | 2 Liters capacity |
| b. Over 2000cc | 3 liters capacity |

4.12 Transmission:

- The transmission mode cannot be changed. A front wheel drive car cannot become a rear wheel drive or four wheel drive and vice versa.
- The gearbox is free but cannot be moved into a different position.
- All cars must have a reverse gear.
- The clutch system is free.
- The differentials are free.
- Axles' ratio is free.

4.13 Suspension:

- All wheels must be suspended. Axles or wheels must not be connected directly to the chassis.
- Springs and dampers are free.
- The mounting points of the suspension to the body shell must remain unchanged. These points can be strengthened by adjunction of material.
- The anti roll bar is free.

- The original collapsible steering column should be kept.
 - The steering column adjusting system must be locked and must be operated only with tools.
- 4.14 Wheels and Tyres: Wheels are free in shape & size but cannot be modified (e.g. cutting making different mounting holes...) Tyres are free provided that they can be mounted on those wheels.
- 4.15 Handbrake: A mechanical or hydraulic properly operating handbrake is compulsory. The use of a “fly off” system is permitted, although a locking system is required.
- 4.16 Chassis / Bodywork:
- The chassis structure can be reinforced, provided the material takes the original shape. Reinforcement bars may be fitted or welded. However it is prohibited to modify the structure – i.e. cutting, trimming, grinding, etc... – under any circumstance.
 - Body work openings, hood, trunk lid and rear doors can be replaced by similar elements having the same shape but in lighter materials however, it is a must to use metal reinforcement plates under the additional fasteners in order to prevent wrenching.
 - The front two doors cannot be replaced and should be kept in their original status.
 - Fenders in their form and material are free and should cover efficiently at least 1/3 of the tire on its complete width.
 - The bodywork should cover all the mechanical components, only the exhaust and air intake piping may project.
 - Any part having an aerodynamic effect must be rigidly secured to the body without any freedom of movement.
 - All elements of the bodywork shall be completely and cleanly finished.
 - Bumpers can only be removed if they are not part of the bodywork.
 - No protruding parts may extend further than the bodywork.
 - Windscreen: The windscreen should be of one piece and made of laminated glass (Triplex).
 - If the original side and rear windows are used, they should be covered by a transparent safety film. The use of tinted or silver safety film is prohibited according the Lebanese traffic regulations. Refer to Appendix J Art 253-11 of the FIA.
 - Side front windows can be replaced by transparent polycarbonate sheets of minimum 3mm thick, with an opening of minimum 300cm².
 - Rear quarter and rear windows can be replaced by transparent polycarbonate elements of at least 3mm thick.
 - Polycarbonate sheets:
 - ✓ Approved material: Makrolon[®], Zelux[®], Plexiglas[®], Lexan[®], Tuffak[®], Calibre[®] or equivalent.
 - ✓ The minimum impact requirement of notched Izod impact strength is 10ft-lb/in (ASTM D256) or 540J/m (ISO 180).
 - ✓ It is mandatory to provide the specifications datasheets of the used polycarbonate sheets to the technical commission (CSN), technical delegate and/or scrutineer upon request.

4.17 Cockpit:

- The front seat(s) can be moved backwards but not beyond the vertical plane of the original rear seat.
- The removing of the dashboard & trimmings is permitted.
- The removing of the driver door trim is permitted but must be replaced with a rigid unflammable protection panel.
- The removing of all other sound proofing trim materials and carpets is permitted.
- The removing of heating and A/C systems is permitted.
- Electrical equipment:
 - Battery mounting in front of the driver and/or co-driver seat is PROHIBITED. Refer to Appendix J art 255-8 for proper battery installation
 - The alternator is free.
 - A starter must be capable of starting the engine at all times; it must be operated by the drivers while normally seated in the car.
 - All cars must be fitted with two stop lights in addition to signal lights (indicators). They must be located symmetrically on either sides of the vehicle and must be mounted in a visible position.
 - A properly operating windscreen wiping system is compulsory, with minimum one blade large enough to clear the vision.

Article 5- Fuel and Combustive:

- -Commercially available petrol or diesel, according to the provisions of Article 259.6.1 of Appendix J, and aviation fuel AVGAS are only permitted as fuel.
- - Only air can be mixed with the fuel as an oxidant.
- - Fuel additives readily available on the market can be added to the fuel.

TECHNICAL REGULATIONS FOR SPEED TEST CARS

Group L

All production vehicles normally commercialized & registered in conformity with the local traffic regulations with a valid “Mécanique” control check & complying with the following:

- Cars should be in excellent condition.
- Only engines from same vehicle manufacturer are allowed.
- A minimum 3 points safety belt in good condition is **MANDATORY**. Homologated harnesses are acceptable if properly fitted.
- Laminated front windscreen is mandatory.
- Crash helmet, homologated to the current year.
- A dual braking system.
- External after market body accessories are acceptable upon the approval of the Scrutineers
- The external internal & general original aspect of the vehicle should be preserved & accepted by the Scrutineers.
- The removing or replacing of any part to decrease weight is **PROHIBITED**.
- The wheels can be replaced by after market ones, as long as they fit & do not exceed the limits of the body.
- Free flow air filters are permitted.
- Hydraulic handbrakes are accepted if fitted properly
- Anti lag systems *i.e.*, *bang bang*, are **PROHIBITED**.
- The original Engine Control Unit (ECU) should be fitted. The use of after-market upgraded unites are **TOTALLY PROHIBITED**.
- Shock absorbers with external oil reservoirs are **TOTALLY PROHIBITED**.
- Brake discs and calipers should be as per **ORIGINALLY EQUIPPED**.
- The noise level on the open road must not exceed 103 dB(A) for an engine rotation speed of 3500 rpm for petrol engines”.
- Convertible cars: Are not eligible, with the exception of “Targa” type convertibles & cars fitted with a roll bar from the factory.
- All SUVs (4X4) trucks, pick ups, Quads motorcycles etc. are not eligible
- As a general rule all cars prepared for rally and/or race events are not allowed to compete in this group.

Amateur group cars are distributed as follows:

- L1: Up to & including 1400 cc.
- L2: Over 1400 & up to including 1600cc.
- L3: Over 1600 & up to including 2000cc. This class includes cars with supercharged 1.4/1.6liters engines originally fitted by the brand manufacturer (*i.e.*: Peugeot 208RC, Renault Clio RS, etc...).
- L4: Over 2000cc. This class includes cars that are subsequently fitted with an aftermarket supercharge/turbo provide that all safety measures have been taken into consideration. The scrutineers have the right to reject any car up to their discretion without having to give any explanation.

For Turbo charged cars the nominal capacity will be multiplied by 1.7.

Group C

All production vehicles normally commercialized whose production has ceased **at least 30 years ago**, and registered in conformity with the local traffic regulations with a valid “Mécannique” control check & complying with the following:

- Cars should be in excellent condition.
- Only engines from same vehicle manufacturer are allowed.
- A minimum 3 points safety belt in good condition is **MANDATORY**. Homologated harnesses are acceptable if properly fitted.
- Crash helmet, homologated to the current year.
- External after market body accessories are acceptable upon the approval of the Scrutineers
- The external internal & general original aspect of the vehicle should be preserved & accepted by the Scrutineers.
- The removing or replacing of any part to decrease weight is **PROHIBITED**.
- The wheels can be replaced by after market ones, as long as they fit & do not exceed the limits of the body.
- Free flow air filters are permitted.
- Hydraulic handbrakes are accepted if fitted properly
- Anti lag systems i.e., bang bang, are **PROHIBITED**.
- The original Engine Control Unit (ECU) should be fitted. The use of after-market upgraded unites are **TOTALLY PROHIBITED**.
- Shock absorbers with external oil reservoirs are **TOTALLY PROHIBITED**.
- Brake discs and calipers should be as per **ORIGINALLY EQUIPPED**.
- The noise level on the open road must not exceed 103 dB(A) for an engine rotation speed of 3500 rpm for petrol engines”.
- Convertible cars: Are not eligible, with the exception of “Targa” type convertibles & cars fitted with a roll bar from the factory.
- All SUVs (4X4) trucks, pick ups, Quads motorcycles etc. are not eligible
- As a general rule all cars prepared for rally and/or race events are not allowed to compete in this group.

Classic cars group vehicles are distributed as follows:

- C1: Up to & including 1400 cc.
- C2: Over 1400 & up to including 1600cc.
- C3: Over 1600 & up to including 2000cc.
- C4: Over 2000 & up to including 3000cc.
- C5: Over 3000cc.

For turbo charged cars, the nominated capacity will be multiplied by 1.4.

Tyres for Amateur (all Classes) and Super Series categories, excluding Pro Series:

Only tires commercially and readily available marked “DOT”, “E” or “e” are accepted. Slick and "molded" tires are NOT permitted. Any type of tire SHOULD be submitted for final approval, latest TWO WEEKS BEFORE the event, to the organizing committee of the event. Acceptance of the said tires is conditioned by the committee’s final approval.

The organisers have the right to reject any tyre without having to give a reason.
For Pro Series; the tyres regulations of the 2018 Lebanese Hill Climb Championship are applied.

Fuel and Combustive:

- Commercially available petrol or diesel, according to the provisions of Article 259.6.1 of Appendix J, and aviation fuel AVGAS are only permitted as fuel.
- Only air can be mixed with the fuel as an oxidant.
- Fuel additives readily available on the market can be added to the fuel.

This present Appendix C supersedes and replaces all the previous issued editions and come into force on **January 1st 2018.**

APPENDIX I:

RECOMMENDED MOUNTING OF ON-BOARD CAMERAS INTERIOR / EXTERIOR

1- INTERIOR MOUNT

The mounting should be of a rigid type, placed in the centre behind the back of the seats.

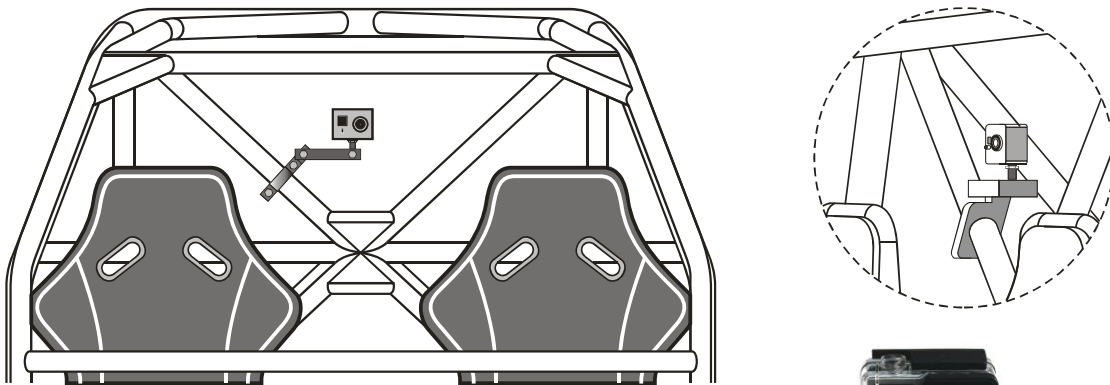

Handlebar Mount



For pencil type cameras, they can be mounted on the front rollbar windscreen pillar, the control unit should be fixed on the floor pan behind the seats. (Similar to battery fixation)

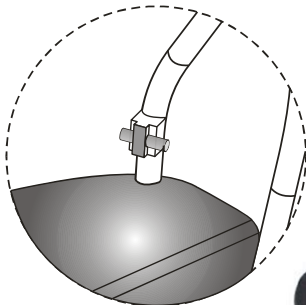

On front Rollbar

OR

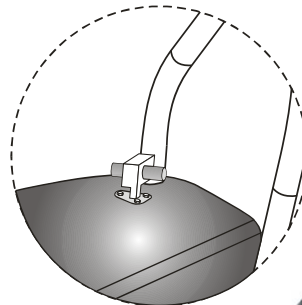

On dashboard



APPENDIX I: (cont.)

2- EXTERIOR MOUNT

A support bracket of 40mm. fixed by screws with a reinforcement plate of minimum 3mm thick and a surface of 120 cm² should be used

IMPORTANT: The reinforcement plate should be placed from inside the body work in order to reinforce the support area.

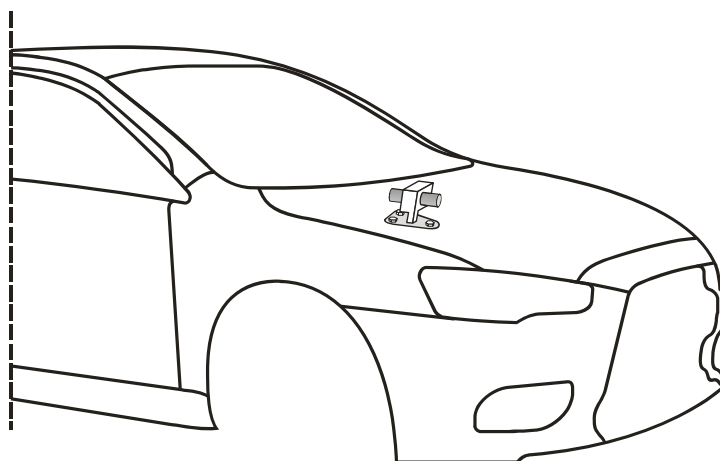

3- PROHIBITED MOUNTINGS



This page has been left blank intentionally.